

---

## 1.2.1 VitalSensors VS-1000 Sensor System 4-20mA Application Guide

Connecting a VitalSensors Instrument to 4-20mA Current Loop Network

---

- Objective:**
- Become familiar with the instrument wiring requirements and 4-20mA
  - Become familiar VS-1000 Sensor System and 4-20mA
- 

- Equipment:**
- PC running Windows XP®, Windows Vista® or Windows 7®
  - VS-3000 Sensor System
- 

While every effort was made to verify the following information, no warranty of accuracy or usability is expressed or implied.

***VS-1000 Sensor System 4-20mA current loop communications***

The *VS-1000 Sensor System* supports four channels of 4-20mA current loop communications.

*VS-1000 Sensor Systems* shipped from the plant with 4-20mA communications are configured at the factory with default communication settings – see Output Assignments charts below. The output assignments can be changed in the *Sensor Management Console* software application. Instructions on how to do this is in the *VS-1000 Sensor System* user guide contained in the VitalSensors documentation CD shipped with each system.

***Sensor Management Station 4-20mA Current Loop Side Connector***

Included with the shipment is the appropriate connector with wiring instructions for the current loop side. Once the system is permanently fixed at a location and the sensor is connected the next step is to connect the 4-20mA current loop side wires to the Turck BS 8181-0 connector supplied with the system. The following are the wiring instructions for the connector. **4-20mA cable should be 8 conductor, 18 gauge shielded twisted pair.**

Connector: Turck BS 8181-0 (supplied)  
 (view of pin connections inside connector)  
 Accepts 4-8 mm cable diameter

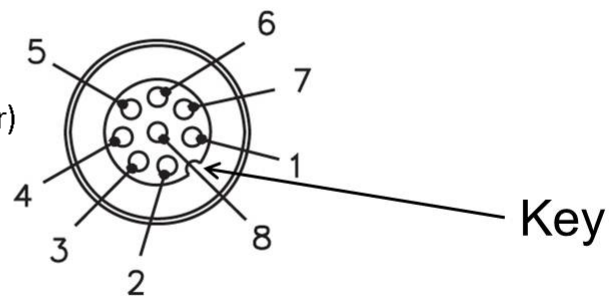

*Fig. 1*

**Connect 4-20mA current loop connector to Fieldbus port on the underside of the *Sensor Management Station*. Turn on the system after all wiring is complete. The sensor must also be connected to the system.**

Figure 1 shows the pin assignments for the 4-20ma wires inside the supplied connector.

After the current loop side connector is wired it should be fixed to the connector on the underside of the *Sensor Management Station* marked Fieldbus. Please note that the connector is “keyed” and can only be inserted one way.

The system should then be powered on and 4-20mA communications will begin automatically.

The latest *VS-1000* Sensor System 4-20mA communications implementation uses a microprocessor based complete digital to current loop output converter designed to meet the needs of the industrial control market. It provides a high precision (16 bit, 64,000 step), fully integrated, low cost communications solution. Output ranges can be set and the 4-20mA communications is self calibrating without the requirement for manual adjustments.

**Sensor Management Station Internal 4-20mA Wiring Diagram**

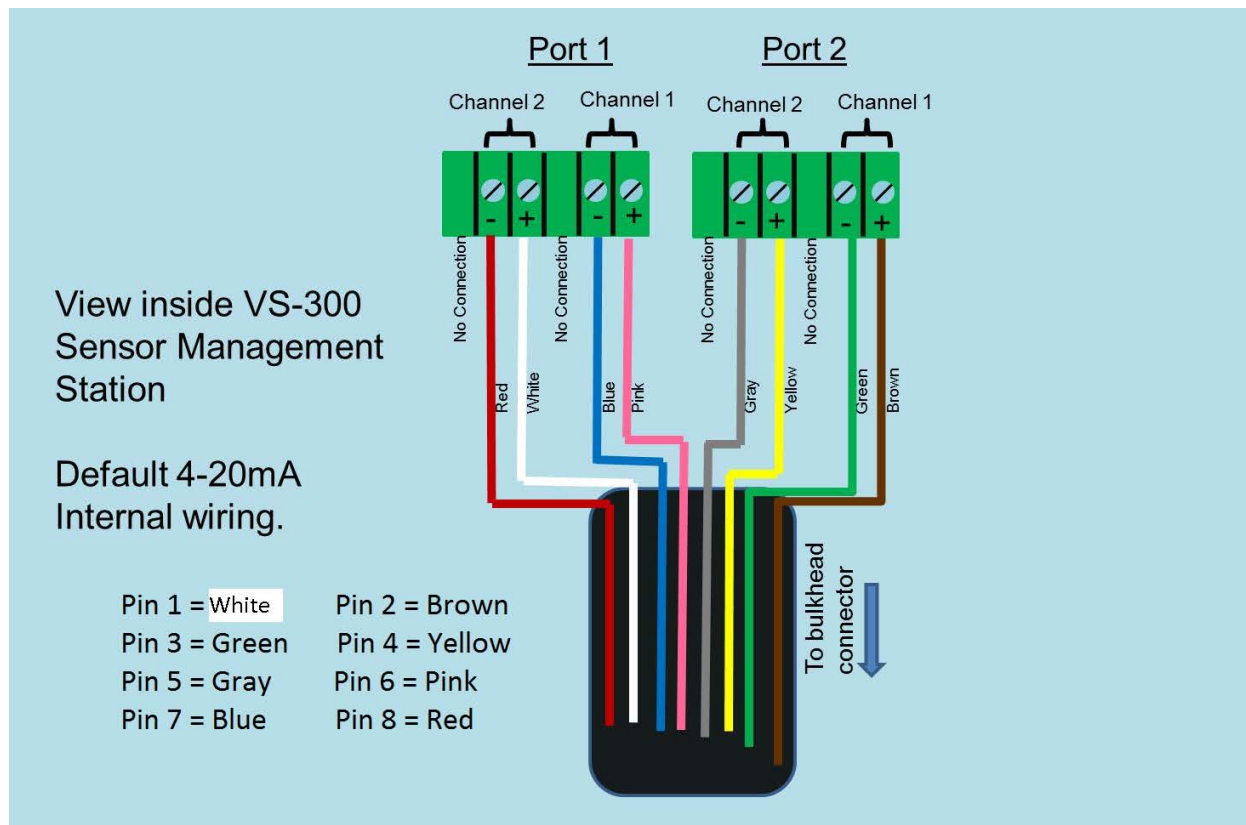

Figure 2

On *VS-1000* Sensor Systems only Port 1 and Port 2 provide redundant output for the Concentration and Temperature. The table below explains the settings.

## VS-1000 Settings Table

Default Concentration	4-20mA Port	4-20mA Channel	Associated Connector Pins
Concentration	1	1	6 (+), 7 (-)
Temperature	1	2	1 (+), 8 (-)
Concentration	2	1	2 (+), 3 (-)
Temperature	2	2	4 (+), 5 (-)

### Sensor Management Console Settings Menu Example

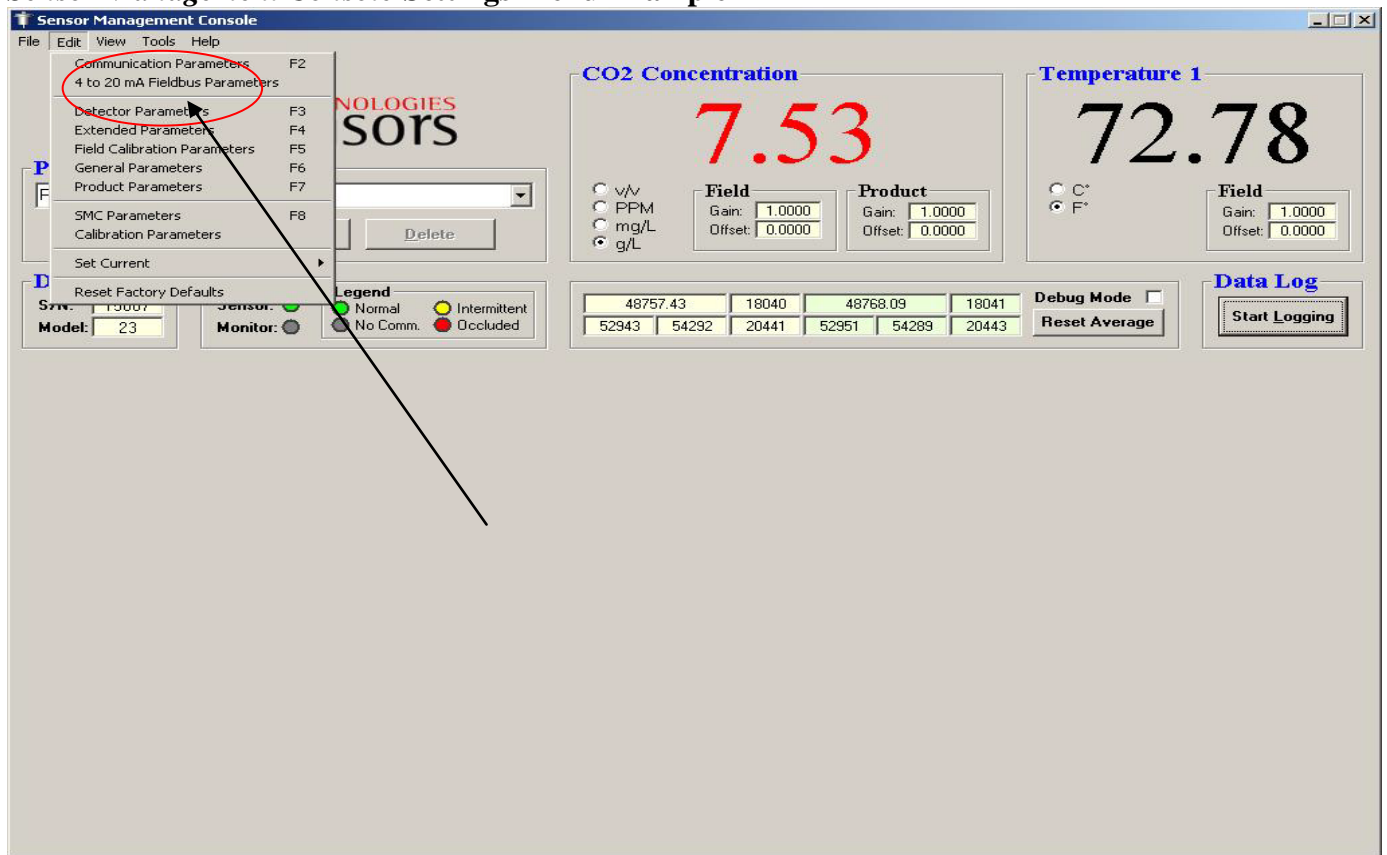

The *Sensor Management Console* settings menu is accessed the following way. A personal computer and Ethernet cable is required. The MS Windows application allows a user to log onto the system.

1. On the main *Sensor Management Console* screen click on “EDIT”
2. Click on “4-20mA Fieldbus Parameters”
3. You see Fig. 3
4. Minimum and Maximum output scales per channel can be edited – click Accept
5. Concentration by channel can be edited – click Accept

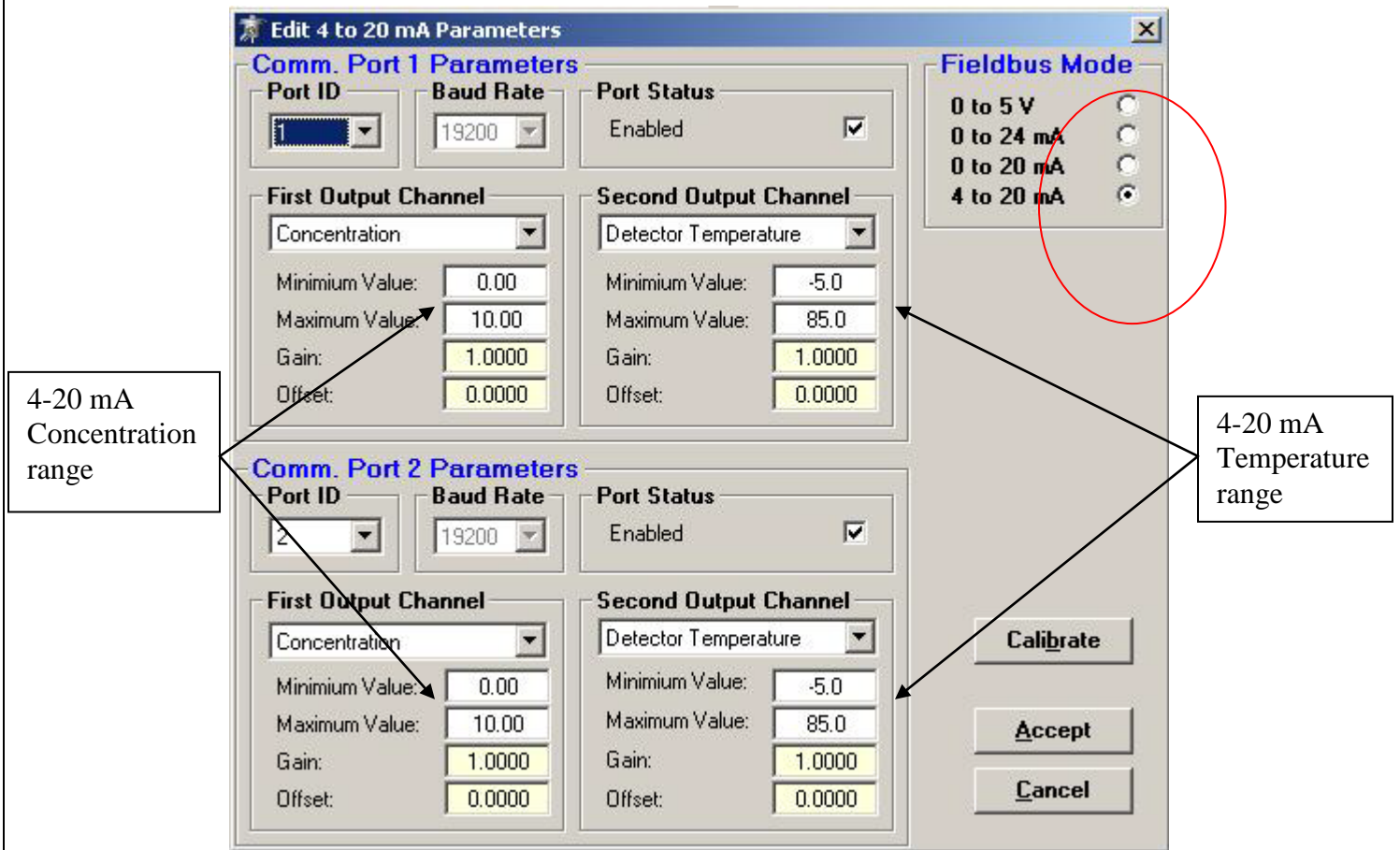

Fig. 3

**The default values for the system shipped to you are contained in the system paperwork contained in the system shipping box. They are set at the factory using the customer Application Questionnaire.**