

2.2.3 VitalSensors *Sensor Management Station* Remote/Relay Field Wiring

Note: This guide is applies only to VS-3000 (up to 3 concentrations) systems shipped on or after 12/1/2011

Connecting a VitalSensors Remote-IN/Relay-OUT DIO to Field Wiring and PLC

Objective:

- Become familiar with the instrument wiring requirements for the VS-300 Remote-IN/Relay-OUT Field Wiring
- Become familiar with PLC signal requirements necessary for the VS-300 SMS to make automatic product/brand changes and line status.

Equipment:

- 3000 System (shipped after 12/1/2011 – or receiving software updates after 12/1/2011)
- PLC and Field Wiring

While every effort was made to verify the following information, no warranty of accuracy or usability is expressed or implied.

Overview: *Sensor Management Station*: Field wiring schematic



Electrical connections should only be implemented by authorized and experienced personnel!

Power switch OFF prior to installation!

The *Sensor Management Station* is **optionally** equipped with a remote-IN/relay-OUT digital I/O board. Through simple control wiring, different functions of the *SMS* can be executed from a remote control system (PLC). For example, products or brands can be changed on the *SMS* automatically through a PLC signal and alarms can be sent to the PLC from the *SMS*.

Connection Wiring Requirements:

- Cable: 17-20 conductor shielded cable; 6-8mm cable diameter (customer provided)
- Female Connector (provided with system): Turck, Inc. part number: BK 19-0
- Customer is responsible for wiring connector provided
- Male Connector (provided with system) prewired on bottom of system.
- **Isolated Digital Inputs:** number of inputs Eight or Sixteen (DIO board dependent)
- Voltage Range: 3 to 31 VAC or VDC (40 to 10000 Hz)
- **Isolated Digital Outputs:** number of outputs Eight or Sixteen (DIO board dependent) Solid State FETs (off @power up)
- Voltage Range 5-35 VDC for continuous use

Remote-IN Operation:

The *Sensor Management Station* provides functionality to change brands/products remotely using a PLC and eight “switches”. Up to 64 different “Product Ids” can be selected by sending the appropriate HIGH/LOW signal from the PLC. The “switch” combinations for selecting products are shown in **Table 1**.

Note: The Sensor Management Station comes pre-loaded with one “Product Id” by default (using default gain and offset). Using the *Add/Remove Products* menu in the *VS-3000 Dashboard* a user can configure additional products/brands. Products will be added to the *Sensor Management Station* “product list” in the order which they are entered. **Table 1** below displays “switch” positions for products based on order of entry.

* If a product is removed and a new product created, the new product takes the lowest available index in the “product list” and assumes the corresponding “switch” positions

** Multiple products can also be added or removed simultaneously by manually writing to “ProductList.txt” located in the D:/Products folder

Explanation of “Switch” functionality:

Sw0 controls whether or not the *Sensor Management Station* receives input signals from the PLC. When Sw0 is HIGH the *Sensor Management Station* ignores ALL inputs. When Sw0 is LOW, the *SMS* will read the input command (either a product code or “hold command”).

The *SMS* assumes that input signals will be static for the duration of the product run when Sw0 is LOW (active position). If Sw0 is HIGH (inactive position) the *SMS* will ignore ALL inputs from the PLC until the Sw0 is reactivated. During this period the last known input state will be maintained. When Sw0 is re-activated, the “switch” positions at the time of activation will be read as input.

*** For example if the *SMS* is set to Product 3 and Sw0 is set to HIGH (inactive position), then the system continues to assume Product 3 is running.

Sw1 indicates a line stop signal in the HIGH (active) position. “Product IDs” cannot be received by the *SMS* if Sw1 is set to HIGH by the PLC. Setting Sw1 LOW (inactive) indicates a line start or “hold release.” Products/brands can be selected when Sw1 is in the LOW setting. “Error code” 63 will be sent over relay.

Note: If PLC sends a product ID that does not exist in previously created list of products the *SMS* display will flash “Invalid Product ID.” Additionally, the Relay-OUT alarm will show an “error code” indicating the input signal is invalid (See **Table 2**). Until a valid signal is received from the PLC no adjustments can be made to output parameters. When Product Id is invalid, the sensor will continue to output data under the assumption that product gain is 1.0 and offset is 0.0. CO2 correction for *Specific Gravity* is 1. CO2 correction for Ethanol is 0 (if applicable).

VS-3000 Dashboard Software vs. Remote-IN Control for product selection:

There are 2 methods for changing products; using *Sensor Management Station* functionality **or** via digital input signal from PLC. Products are selected on the screen or via the *SMS* push-buttons by default. Product Ids will not be received over digital input when *SMS* control is enabled. To enable products selection over the fieldbus, a setting called *Fieldbus Set Product Enabled* must be active; this option is located in the *Remote/Relay Parameters* menu (see **Figure 1**). Product selection can only be performed using one mode. This is by design to avoid conflicts between the *SMS* and PLC. When *Fieldbus Set Product Enabled* is selected, products cannot be changed over the push-buttons or *VS-3000 Dashboard* screen. However, the user always has the ability to adjust gains and offsets using the *VS-3000 Dashboard* software or *SMS* push buttons. The only exception to this is if an Invalid

Product Id is received from the PLC, in this case product gain and offset changes are disabled and are not applicable. Push buttons are disabled until a valid signal is received from PLC.

Chart 1:

Product ID	Sw0	Sw1	Sw2	Sw3	Sw4	Sw5	Sw6	Sw7
Product 1 (user can modify id)	low	low	low	low	low	low	low	Low
Product 2 (user can modify id)	low	low	HIGH	low	low	low	low	low
Product 3 (user can modify id)	low	low	low	HIGH	low	low	low	low
Product 4	low	low	HIGH	HIGH	low	low	low	low
Product 5	low	low	low	low	HIGH	low	low	low
Product 6	low	low	HIGH	low	HIGH	low	low	low
Product 7	low	low	low	HIGH	HIGH	low	Low	low
Product 8	low	low	HIGH	HIGH	HIGH	low	Low	low
Product 9	low	low	low	low	low	HIGH	Low	low
Product 10	low	low	HIGH	low	low	HIGH	Low	low
Product 11	low	low	low	HIGH	low	HIGH	Low	low
Product 12	low	low	HIGH	HIGH	low	HIGH	Low	low
Product 13	low	low	low	low	HIGH	HIGH	Low	low
Product 14	low	low	HIGH	low	HIGH	HIGH	Low	low
Product 15	low	low	low	HIGH	HIGH	HIGH	Low	low
Product 16	low	low	HIGH	HIGH	HIGH	HIGH	Low	low
Product 17	low	low	low	low	low	low	HIGH	low
Product 18	low	low	HIGH	low	low	low	HIGH	low
Product 19	low	low	low	HIGH	low	low	HIGH	low
Product 20	low	low	HIGH	HIGH	low	low	HIGH	low
Product 21	low	low	low	low	HIGH	low	HIGH	low
Product 22	low	low	HIGH	low	HIGH	low	HIGH	low
Product 23	low	low	low	HIGH	HIGH	low	HIGH	low
Product 24	low	low	HIGH	HIGH	HIGH	low	HIGH	low
Product 25	low	low	low	low	low	HIGH	HIGH	low
Product 26	low	low	HIGH	low	low	HIGH	HIGH	low
Product 27	low	low	low	HIGH	low	HIGH	HIGH	low
Product 28	low	low	HIGH	HIGH	low	HIGH	HIGH	low
Product 29	low	low	low	low	HIGH	HIGH	HIGH	low
Product 30	low	low	HIGH	low	HIGH	HIGH	HIGH	low
Product 31	low	low	low	HIGH	HIGH	HIGH	HIGH	low
Product 32	low	low	HIGH	HIGH	HIGH	HIGH	HIGH	low
Product 33	low	low	low	low	low	low	Low	HIGH
Product 34	low	low	HIGH	low	low	low	Low	HIGH
Product 35	low	low	low	HIGH	low	low	Low	HIGH
Product 36	low	low	HIGH	HIGH	low	low	Low	HIGH
Product 37	low	low	low	low	HIGH	low	Low	HIGH
Product 38	low	low	HIGH	low	HIGH	low	Low	HIGH
Product 39	low	low	low	HIGH	HIGH	low	Low	HIGH
Product 40	low	low	HIGH	HIGH	HIGH	low	Low	HIGH
Product 41	low	low	low	low	low	HIGH	Low	HIGH
Product 42	low	low	HIGH	low	low	HIGH	Low	HIGH
Product 43	low	low	low	HIGH	low	HIGH	Low	HIGH
Product 44	low	low	HIGH	HIGH	low	HIGH	Low	HIGH
Product 45	low	low	low	low	HIGH	HIGH	Low	HIGH
Product 46	low	low	HIGH	low	HIGH	HIGH	Low	HIGH

Product 47	low	low		HIGH	HIGH	HIGH	Low	HIGH
Product 48	low	low	HIGH	HIGH	HIGH	HIGH	Low	HIGH
Product 49	low	low	low	low	low	low	HIGH	HIGH
Product 50	low	low	HIGH	low	low	low	HIGH	HIGH
Product 51	low	low	low	HIGH	low	low	HIGH	HIGH
Product 52	low	low	HIGH	HIGH	low	low	HIGH	HIGH
Product 53	low	low	low	low	HIGH	low	HIGH	HIGH
Product 54	low	low	HIGH	low	HIGH	low	HIGH	HIGH
Product 55	low	low		HIGH	HIGH	low	HIGH	HIGH
Product 56	low	low	HIGH	HIGH	HIGH	low	HIGH	HIGH
Product 57	low	low	low	low	low	HIGH	HIGH	HIGH
Product 58	low	low	HIGH	low	low	HIGH	HIGH	HIGH
Product 59	low	low	low	HIGH	low	HIGH	HIGH	HIGH
Product 60	low	low	HIGH	HIGH	low	HIGH	HIGH	HIGH
Product 61	low	low	low	low	HIGH	HIGH	HIGH	HIGH
Product 62	low	low	HIGH	low	HIGH	HIGH	HIGH	HIGH
Product 63	low	low	low	HIGH	HIGH	HIGH	HIGH	HIGH
Product 64	low	low	HIGH	HIGH	HIGH	HIGH	HIGH	HIGH
HOLD (freeze outputs)	low	HIGH	<i>Current</i>	<i>Product</i>		<i>and</i>		
HOLD cancel	low	low	<i>Current</i>	<i>Product</i>		<i>and</i>		

- Part Number: **VS-1000DIO - 1** (board supports 64 products)

Relay-OUT Codes:

The *Sensor Management Station* has the ability to output alarms to a PLC when certain conditions arise during a product run. Alarms are output using eight bits to display binary codes. Codes are displayed on the *VS-3000 Dashboard* software as well as over Fieldbus. Each code corresponds to a specific condition. See **Table 2**.

Bits are numbered 0-8; bits 0 and 1 are reserved strictly for the most critical alarms; *Sensor Disconnected* and *Sensor Occluded* respectively (there is also a redundant “output code” for each of these conditions). The next most significant output code is *Fieldbus Serial Port Error* (which requires a system re-start) followed by *Invalid Product*; this condition occurs when the PLC sends an invalid product code to the *SMS*. “Output codes” are sent as binary via “bits” 2-7.

“Output codes” are sent in the order stated in **Table 2**. Lower “output code” numbers have priority if multiple error conditions are present. Codes can be enabled/disabled via the *Remote-Relay Settings* menu in the *VS-3000 Dashboard* software (see **Figure 1**). If two error conditions exist and the lower number code is disabled, the higher “output code” will be displayed and the lower code ignored. The only exception is “alarm codes” #20, 21 & 63 which take priority over everything except for *Sensor Disconnected* in that order.

Note: VS-3000 (up to 3 concentrations) may use “output codes” for *Ch.1*, *Ch. 2*, and *Ch. 3*. If a code is not applicable, the code description is *Unassigned*. Codes are shown in **Table 2**.

Figure 1:

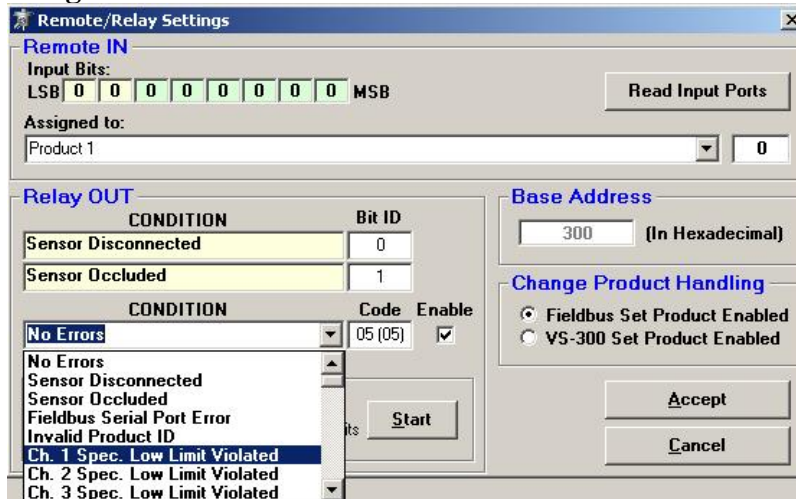

Remote OUT – “Bit” Assignment:

“High” level on a particular output indicates a specific sensor or process problem:

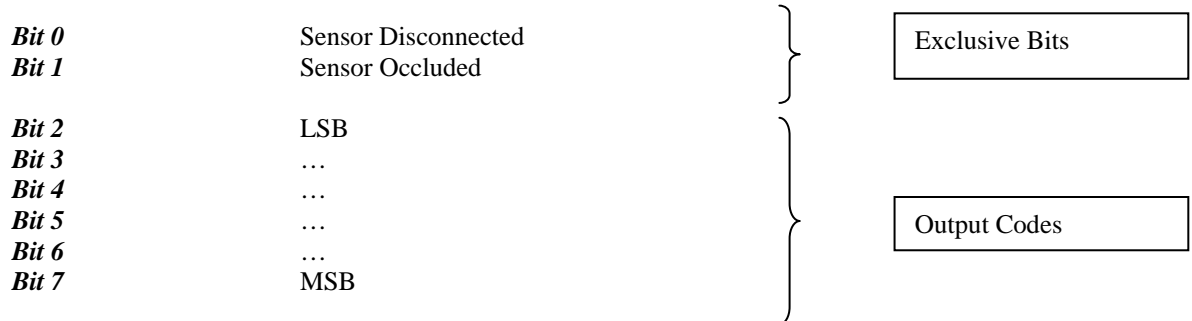

Table 2:

“Single-Bit” Errors (sent to PLC via “bits” 0 and 1)			
Alarm #	Description		Exclusive Output Bit H / L denotes “high” / “low” signal
n/a	Sensor Disconnected	Sensor Alarms	H , L, L, L, L, L, L, L
n/a	Sensor Occluded		L, H , L, L, L, L, L, L
“Multiple-Bit” Output Codes (sent to PLC via “bits” 2-7)			
Alarm #	Description	Comments	0, 1, 2, 3, 4, 5, 6, 7 “high” / “low” bit signal
0	No Errors	Good State	L, L, L, L, L, L, L, L
1	Sensor Disconnected (redundant code)	Sensor Alarms	H , L H , L, L, L, L, L, L
2	Sensor Occluded (redundant code)		L, H L, H , L, L, L, L, L
20	Disk Is Full	SMS Alarms	L, L L, L, H , L, H , L, L
21	Low Disk Space		L, L H , L, H , L, H , L, L
63	System on Hold	User Alarms	L, L H , H , H , H , H , H , H
3	Fieldbus Serial Port Error (requires re-boot)		L, L H , H , L, L, L, L, L
4	Invalid Product ID		L, L, L, L, H , L, L, L, L
5	Sensor Ch. 1 Spec Low Limit Violated	Process Alarms (Spec. Limits)	L, L H , L, H , L, L, L, L
6	Sensor Ch. 2 Spec Low Limit Violated		L, L L, H , H , L, L, L, L
7	Sensor Ch. 3 Spec Low Limit Violated		L, L H , H , H , L, L, L, L
8	Sensor Ch. 1 Spec High Limit Violated		L, L L, L, L, H , L, L, L
9	Sensor Ch. 2 Spec High Limit Violated		L, L H , L, L, H , L, L, L
10	Sensor Ch. 3 Spec High Limit Violated		L, L L, H , L, H , L, L, L
11	Sensor Ch. 1 Control Low Limit Violated	Process Alarms (Control Limits)	L, L H , H , L, H , L, L, L
12	Sensor Ch. 2 Control Low Limit Violated		L, L L, L, H , H , L, L, L
13	Sensor Ch. 3 Control Low Limit Violated		L, L H , L, H , H , L, L, L
14	Sensor Ch. 1 Control High Limit Violated		L, L L, H , H , H , L, L, L
15	Sensor Ch. 2 Control High Limit Violated		L, L H , H , H , H , L, L, L
16	Sensor Ch. 3 Control High Limit Violated		L, L L, L, L, L, L, H , L
17	4-20 Ports Disabled	4-20mA Alarms	L, L H , L, L, L, L, H , L
18	4-20 Port 1 Disabled		L, L L, H , L, L, L, H , L
19	4-20 Port 2 Disabled		L, L H , H , L, L, L, H , L

Alarms displayed in order of output priority

Input Wiring

Sample for 1 through 8 input circuits

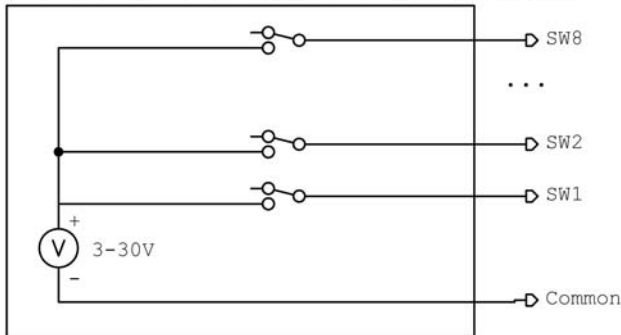

The above diagram shows how two of the seven “switches” (Sw1-Sw8) must be wired. As shown, the PLC supplies the switching voltage and the switching logic is either HIGH (voltage) or low (ground). Six (e.g. S3-S8) switches are needed to provide for 64 products on the **VS-1000DIO-1** board

Output Wiring

Sample 1 of 8 alarms or outputs

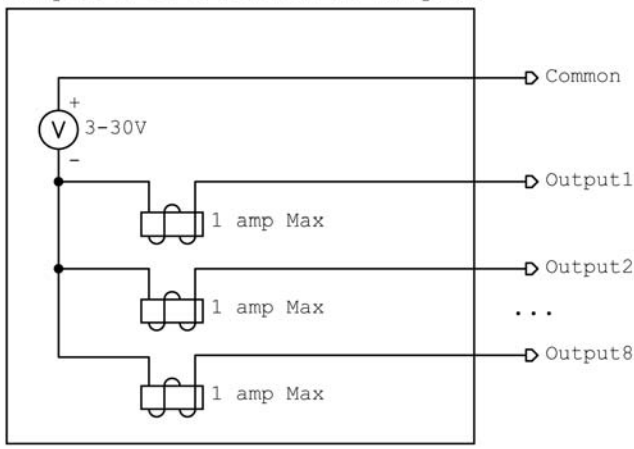

The above diagram shows the wiring for the user output circuit. A separate circuit is required for each of the desired outputs used. The PLC supplies voltage and the *SMS* will provide a “contact” closure for output, up to 1 amp. Diagram is for the **VS-1000DIO-1** board.

|

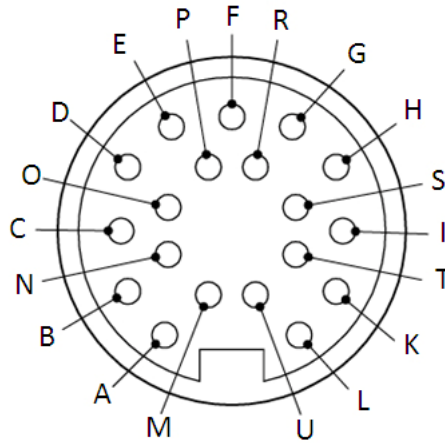

Turck BK-19 female field-wireable connector shown from solder cup side – one connector is provided with each system. The customer wires this connector to the cable (customer provided).

Connections:

Pin	Connection
A	Input common (ground)
B	Sw1 Bit 0 B
C	Sw2 Bit 1 B
D	Sw3 Bit 2 B
E	Sw4 Bit 3 B
F	Sw5 Bit 4 B
G	Sw6 Bit 5 B
H	Sw7 Bit 6 B
I	Sw8 Bit 7 B
K	Output common
L	Output 1 Bit 7
M	Output 2 Bit 6
N	Output 3 Bit 5
O	Output 4 Bit 4
P	Output 5 Bit 3
R	Output 6 Bit 2
S	Output 7 Bit 1
T	Output 8 Bit 0
U	Spare Ground

+3 to 30V



Attached is a wiring diagram detailing the Digital I/O connections as we have setup in our lab. It includes toggle switches, LEDs and power source.

Substitute your PLC switches for the switches shown, substitute alarm relays for the LEDs (if used), and you must use a power source for both input and output.

We provide the Turck BK19-0 connector as shown in the schematic.

Pre-wired cables up to 250 ft available upon request.